



SCHÖNBERG WALL-MOUNTING KIT

To prepare the speakers for wall mounting

1. It is advised to put on the enclosed gloves so as to avoid the potential of fingerprint oils staining the cabinet during assembly.
2. It is recommended to start with the bottom of the speaker.
3. Place the bottom mounting inlay on the speaker, so that the two holes for the two bolt sockets line up.

ATTENTION:

The two inlays are slightly different for use on each of the respective sides. In order to mount the inlays correctly the three conical milled indent points must be visible and the mounting bolts able to be inserted.

The bottom-side of each inlay is covered with adhesive tape. This adhesive is intended for use when attaching the top inlay only. Please do not remove the protective film from the adhesive from the inlay that is to be attached to the bottom of the speaker. This will assure, that should positioning on the floor be desired in the future, the inlay can be easily removed, allowing for the attachment of the floor mounting stand.

4. Attach the appropriate inlay with the two M6 x 20 mm bolts using the Allen wrench (hexagonal tool).

BOTTOM

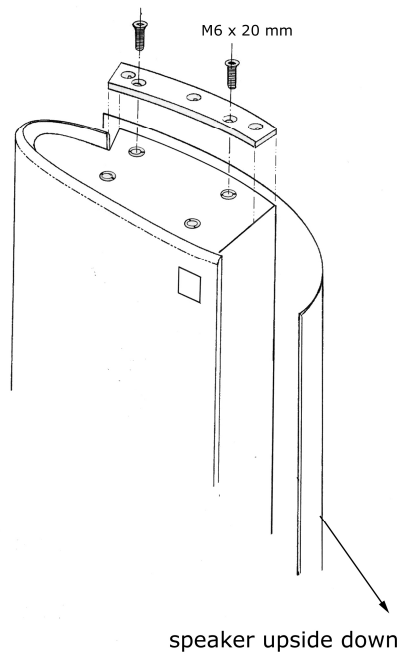

5. Turn the speaker over in order to attach the other inlay to the top of the speaker.

ATTENTION:

Before putting on the inlay, please make sure that the surface of the speaker is clean so that the adhesive tape will adhere completely to the cabinet. To clean the surface, use a dry cloth with a little rubbing alcohol. Be careful to avoid the use of oily detergents or any other cleaning product that may prevent the adhesive from sticking to the cabinet surface.

Be certain to determine the correct position of the inlay prior to removing the protective film from the adhesive tape. Position the inlay so that it is against the rear cabinet wall and centered side-to-side on the cabinet top (as seen in the drawing when you turn over the page).

Do not forget to remove the protective film from the adhesive tape as it ensures that the inlay will not move while the screws that hold it in place are inserted after being carefully positioned on the speaker.

6. After removing the protective film from the adhesive tape, press the inlay down firmly, so that the adhesive has solid and complete contact with the body of the speaker.

7. Secure the inlay with the two 4.0 x 15 mm woodscrews (see drawing).

A drill, fitted with a Phillips screw driving bit, can be used, but should not be necessary as the wood screws are relatively easy to insert with a screw-driver and normal hand pressure.

It may be helpful to stabilize the wood screws with a hammer blow first. Should a drill be used, take care not to strip out the cabinet material by overtightening.

ATTENTION:

Please be aware, that inserting the screws will result in permanent holes in the top surface of the speaker.

At some future date, should the floor mounting feet be used, simply leave the inlay attached to the top of the speaker, to prevent the screw holes from being visible.

Inserting the screws will cause no harm to the performance of the speaker, as its cabinet will remain airtight.

UPPER SIDE

Please remove the protective film from the adhesive tape.

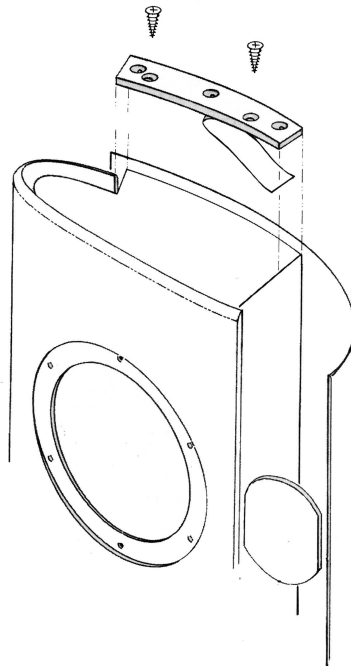

To attach the wall-mounting device to the wall:

ATTENTION:

SCHÖNBERG must always be mounted vertically, and never installed in a horizontal position.

Because of its overall weight, should the speaker be installed horizontally, it could fall out of the bracket as the hold down bolts may loosen over time.

For best performance, it is recommended that the speakers be angled toward the listening position. This means that special attention must be paid when mounting the brackets.

It is recommended that before the brackets are attached to the wall that the speakers in the brackets be held up to wall to verify the correct position of the bracket and the conical point position that is to be used to mount the speaker in the bracket.

If you have chosen to mount the speakers with the tweeters on the inside, mount the bracket with the thin flat profile to the inside. If mounting the speakers with the tweeters on the outside, mount the bracket with the thin flat profile to the outside.

Warning:

The most secure means of attaching the wall-mounting bracket to the wall is by screwing into a stud. Should a stud not be available be sure to use all four of the mounting anchors.

Further, when attaching to a sheet-rock wall board, be certain to use the larger, metal "American" anchor to ensure a solid and permanent mounting.

1. First mark the position on the wall using the four holes of the wall-mounting bracket as a guide. Use a level placed tightly against the bracket while making the marks to ensure that the bracket will be mounted properly.
2. After drilling the holes, and if the bracket is not being mounted into a stud, screw the four anchors firmly and completely into the wall.
3. Now fix the wall-mounting bracket to the wall, either by using the provided wood-screws into a stud or into the appropriate anchor.

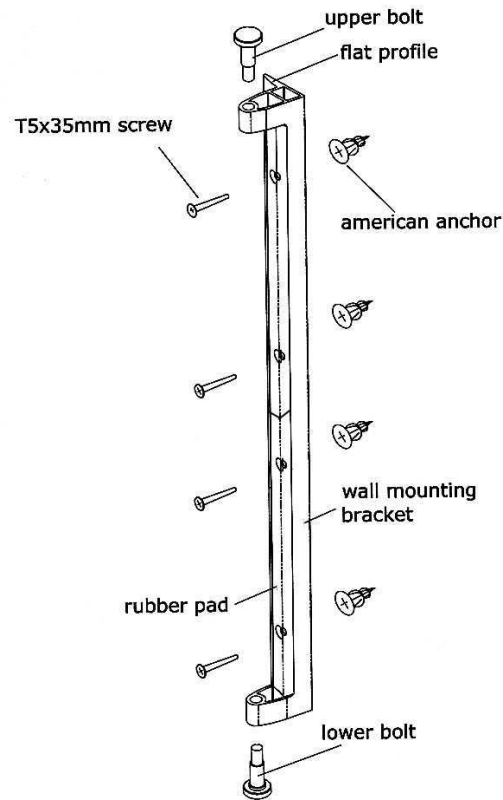

To attach the speaker to the wall-mounting device:

1. Please put on the enclosed gloves to avoid the potential of fingerprint oils staining the cabinet during assembly.
2. Insert the lower conical tipped bolt inside the wall-mounting bracket completely with the Allen wrench (hexagonal tool).

ATTENTION:

The accessories box includes two plastic conical sockets, which you can put on the conical point of the bolts to avoid scratching the inlays while determining final positioning of the speaker. Once the preferred position is found, they may be removed, or left in place.

3. After you have chosen a position, place the speaker in a way that the lower conical tipped bolt fits into the chosen conically milled point on the cabinet inlay.
4. Press the speaker against the rubber-pad of the mounting bracket and attach the speaker to the bracket by tightening completely the upper conical tipped bolt with the Allen wrench (hexagonal tool). Please make sure that you use the same conically milled point on both, lower and upper, inlays.

ATTENTION:

For safety reasons it is recommended that the conical tipped bolts be checked and tightened periodically, or every six months.

ACCESSORIES FOR SCHÖNBERG WALL MOUNTING BRACKET:

WALL MOUNTING DEVICE: 1 pc., for on-wall application.

WALL-MOUNTING INLAY: 2 pcs., with adhesive tape, to place on the speaker for attaching wall-mounting bracket.

CONICAL TIPPED BOLTS: 2 pcs., for connecting the cabinet with the wall-mounting bracket.

PLASTIC CONICAL SOCKETS: 2 pcs., to avoid scratches when inserting and adjusting bolts.

BOLTS: 2 pcs. M6 x 20 mm, for attaching the inlay to the bottom of the cabinet.
2 pcs. 4,0 x 15 mm, for attaching the inlay to the top of the cabinet.

ALLEN WRENCH (hexagonal tool): 2 pcs., for adjusting the screws and bolts.

WOOD SCREWS: 4 pcs., for mounting directly into a stud

METAL WALL MOUNTING ANCHORS AND SCREWS: 4 pcs., for mounting in sheetrock or other wall board wall construction material.

PLASTIC WALL MOUNTING ANCHORS AND SCREWS: 4 pcs., for mounting in plaster or concrete wall construction material.

GLOVES: 2 pcs., for protecting the speaker against fingerprints.

Happy Listening!

Your Vienna Acoustics Team